



**STRONG PARTNERS.
TOUGH TRUCKS.™**



SUPER COMPACT PALLET TRUCKS

PSC1.2

1200 KG

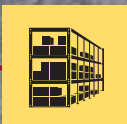

PSC1.2

DISTINGUISHING MARK		HYSTER		DISTINGUISHING MARK	
1.1	Manufacturer (abbreviation)	PSC1.2		1.1	
1.2	Manufacturer's type designation	PSC1.2		1.2	
1.3	Drive: electric (battery or mains), diesel, petrol, fuel gas	Electric (battery)		1.3	
1.4	Operator type: hand, pedestrian, standing, seated, order-picker	Pedestrian		1.4	
1.5	Rated capacity/Rated load	1.2		1.5	
1.6	Load centre distance	600		1.6	
1.8	Load distance, centre of drive axle to fork	886		1.8	
1.9	Wheelbase	1119		1.9	
WEIGHT				WEIGHT	
2.1	Service weight	153 - 155		2.1	
2.2	Axle loading, laden front/rear	438	910	2.2	
2.3	Axle loading, unladen front/rear	114	31	2.3	
TYRES/CHASSIS		Solid rubber / Polyurethane		TYRES/CHASSIS	
3.1	Tyres: solid rubber, superelastic, pneumatic, polyurethane front/rear			3.1	
3.2	Tyre size, front	186 x 50		3.2	
3.3	Tyre size, rear	82 x 60		3.3	
3.4	Additional wheels (dimensions)	75 x 25		3.4	
3.5	Wheels, number front/rear (x = driven wheels)	1x + 2 / 2		3.5	
3.6	Tread, front	369		3.6	
3.7	Tread, rear	371		3.7	
DIMENSIONS				DIMENSIONS	
4.4	Lift	200		4.4	
4.9	Height of tiller arm in driving position min./max.	885	1345	4.9	
4.15	Height, lowered	85		4.15	
4.19	Overall length (pedestrian)	1510		4.19	
4.20	Length to face of forks (pedestrian)	360		4.20	
4.21	Overall width	520		4.21	
4.22	Fork dimensions DIN ISO 2331	55	150 1150	4.22	
4.25	Outside Fork Width	520		4.25	
4.32	Ground clearance, centre of wheelbase	30		4.32	
4.33	Load dimension b 12 x 16 crossways	1000 x 1200		4.33	
4.34.1	Aisle width for pallets 1000mm x 1200mm crossways (pedestrian)	2079		4.34.1	
4.34.2	Aisle width for pallets 800mm x 1200mm lengthwise (pedestrian)	1977		4.34.2	
4.35	Turning radius (pedestrian)	1268		4.35	
PERFORMANCE DATA				PERFORMANCE DATA	
5.1	Travel speed, laden/unladen	4.3	4.8	5.1	
5.1.1	Travel speed, laden/unladen, backwards	4.3	4.8	5.1.1	
5.2	Lift speed, laden/unladen	0.03	0.04	5.2	
5.3	Lowering speed, laden/unladen	0.05	0.02	5.3	
5.8	Max. gradeability, laden/unladen	10	25	5.8	
5.10	Service brake	Electric		5.10	
ELECTRIC - ENGINE				ELECTRIC - ENGINE	
6.1	Drive motor S2 60 minute rating	0.35		6.1	
6.2	Lift motor, S3 15% rating	0.4		6.2	
6.3	Battery according to DIN 43531/35/36 A,B,C, no	No		6.3	
6.4	Battery voltage/nominal capacity K_5	24 / 50		6.4	
6.5	Battery weight	28		6.5	
6.6	Energy consumption according to VDI cycle	0.28		6.6	
DRIVE/LIFT MECHANISM		MOSFET		DRIVE/LIFT MECHANISM	
8.1	Type of drive unit			8.1	
ADDITIONAL DATA				ADDITIONAL DATA	
10.7	Sound pressure level at the driver's seat	67		10.7	

Specification data is based on VDI 2198

TRUCK DIMENSIONS

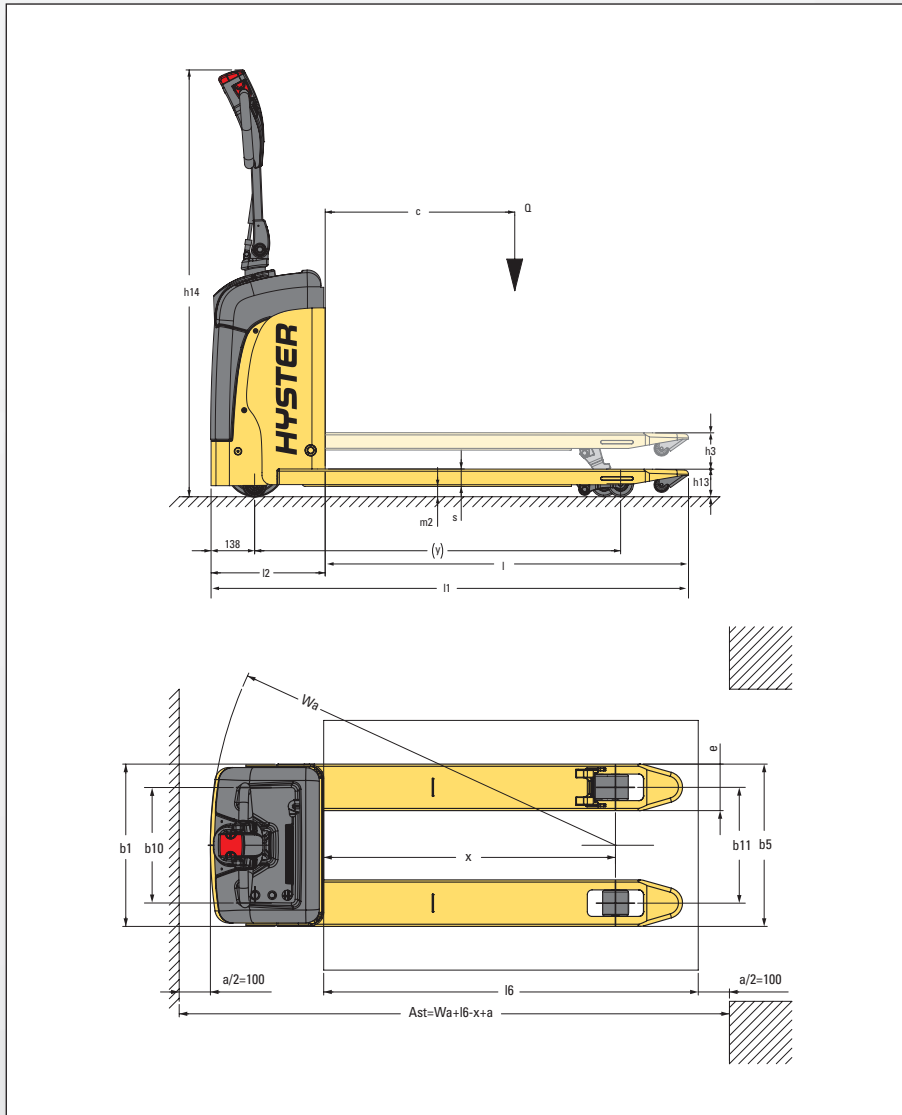

NOTE:

Specifications are affected by the condition of the vehicle and how it is equipped, as well as the nature and condition of the operating area. If these specifications are critical, the proposed application should be discussed with your dealer.

NOTICE

Care must be exercised when handling elevated loads. When the carriage and/or load is elevated, truck stability is reduced. It is important that mast tilt in either direction be kept to a minimum when loads are elevated. Operators must be trained and adhere to the instructions contained in the Operating Manual.

Hyster products are subject to change without notice. Lift trucks illustrated may feature optional equipment.

CE Safety:

This truck conforms to the current EU requirements.

PRODUCT FEATURES

DEPENDABILITY

- MOSFET DC Combi controller for traction and hydraulic controls.
- Battery discharge indicator.
- Welded fork construction makes them highly resistant to torsion and heavy loads.
- In case of collision components and batteries are protected with special designed cover.

PRODUCTIVITY

- Compact chassis design to improve accessibility.
- Operator-friendly tiller head controls for productive load handling.
- Standard anti-roll back system.
- Stabilizing wheels to maximize stability when turning.

- Single load wheels and exit/entry roller to optimize pallet handling.

ERGONOMICS

- Ergonomically tiller head designed for maximum operator comfort.
- Low effort controls ergonomically placed to reduce operator fatigue.
- Adjustable performance setting to suit specific operation conditions.
- Responsive butterfly switches control travel direction, speed and braking allow a smooth start, controlled braking and acceleration.
- Creep-speed function for manoeuvring in dense areas

COST OF OWNERSHIP

- On board charger for on-site recharge.
- Optimized battery packs to ensure maximum time of operation.
- Easy access to motor and key components to reduce downtime.

SERVICEABILITY

- Quick accessibility for exchange of batteries.
- Maintenance free sealed batteries.

STRONG PARTNERS. TOUGH TRUCKS.™

FOR DEMANDING OPERATIONS, EVERYWHERE.

Hyster supplies a complete range of warehouse equipment, IC and electric counterbalanced trucks, container handlers and reach stackers. Hyster is committed to being much more than a lift truck supplier.

Our aim is to offer a complete partnership capable of responding to the full spectrum of material handling issues: Whether you need professional consultancy on your fleet management, fully qualified service support, or reliable parts supply, you can depend on Hyster.

Our network of highly trained dealers provides expert, responsive local support. They can offer cost-effective finance packages and introduce effectively managed maintenance programmes to ensure that you get the best possible value. Our business is dealing with your material handling needs so you can focus on the success of your business today and in the future.



HYSTER EUROPE

Centennial House, Frimley Business Park, Frimley, Surrey, GU16 7SG, England.

Tel: +44 (0) 1276 538500



www.hyster.eu



infoeurope@hyster.com



[/HysterEurope](https://www.facebook.com/HysterEurope)



[@HysterEurope](https://twitter.com/HysterEurope)



[/HysterEurope](https://www.youtube.com/HysterEurope)



HYSTER-YALE UK LIMITED trading as Hyster Europe. Registered Address: Centennial House, Building 4.5, Frimley Business Park, Frimley, Surrey, GU16 7SG, United Kingdom. Registered in England and Wales. Company Registration Number: 02636775.

HYSTER,  and FORTENS are registered trademarks in the European Union and certain other jurisdictions.

MONOTROL® is a registered trademark, and DURAMATCH and  are trademarks in the United States and in certain other jurisdictions.

Hyster products are subject to change without notice. Lift trucks illustrated may feature optional equipment.